

ALUMINIUMROHRE / ALUMINIUM TUBES

FÜR UMSPANNWERKE / FOR ELECTRICAL SUBSTATIONS



ANWENDUNGEN / USES

Aluminiumrohre für Umspannwerke zur elektrischen Stromversorgung.
Aluminium tubes for outdoor electrical distribution substations.

ZUTREFFENDE NORMEN / APPLICABLE STANDARDS

EN 573 / EN 755 / DIN 40501 / DIN 43670

ZUTREFFENDE NORMEN / PHYSICAL PROPERTIES

Tabelle 1 / Table 1

Physische Eigenschaften / Physical properties	Qualität / Quality
Korrosionsbeständigkeit / Resistance to corrosion	Sehr gut / Very good
Kurzschlussfestigkeit / Short circuit resistance	Gut / Good
Schweißbarkeit / Weldability	Gut / Good
Umformbarkeit / Formability	Gut / Good
Eloxiererngung / Anodizing capacity	Sehr gut / Very good
Spanbarkeit / Machineability	Gut / Good

ELEKTRISCHE UND MECHANISCHE EIGENSCHAFTEN / ELECTRICAL AND MECHANICAL PROPERTIES

Tabelle 2 / Table 2

Eigenschaften (Standardwerte) / Properties (Standard values)	Legierung und Härtung / Alloy and tempering	
	6063-T6	6101-T6
Wärmeleitfähigkeit (W/m·K) / Thermal conductivity (W/m·K)	201	218
Elektrische Leitfähigkeit bei 20 °C: (% IACS) / Electrical conductivity at 20°C: (% IACS)	53	57 (min. 55) / 57 (min. 55)
Elektrischer Widerstand bei 20 °C: ($\mu\Omega\cdot m$) / Electrical resistivity at 20°C: ($\mu\Omega\cdot m$)	0,0325	0,0308
Temperaturkoeffizient des elektrischen Widerstands bei 20 °C: (K-1) / Temperature coefficient of the electrical resistance at 20°C: (K-1)	0,0035	0,00370 (min. 0,00363) / 0,00370 (min. 0,00363)

CHEMISCHE ZUSAMMENSETZUNG / CHEMICAL COMPOSITION

Tabelle 3 / Table 3

Legierung / Alloy	Chemische Elemente / Chemical elements									Andere Elemente / Other elements	
	Si	Fe	Cu	Mn	Mg	Cr	Zn	Ti	B	Jeweils / Each	Gesamt / Total
6063	0,2-0,6	0,35	0,10	0,10	0,45-0,90	0,10	0,10	0,10	-	0,05	0,15
6101-B	0,3-0,70	0,50	0,10	0,03	0,35-0,80	0,03	0,10	-	0,06	0,03	0,10

GEFORMTE ROHRE / FORMED TUBES

Abb. 1 / Fig.1



Tabelle 4 / Table 4

Empfohlene Parameter nach REE: / Parameters recommended by REE:		
Rohrdurchmesser / Tube diameters	Gerader Abschnitt / Straight section	Mindestbiegeradius / Minimum curving radius
200/184 mm	700 mm	900 mm
150/134 mm	700 mm	800 mm
120/104 mm	600 mm	700 mm
100/88 mm	600 mm	500 mm
63/47 mm	350 mm	400 mm

International Bronmetal, S.A. liefert auch gebogene und überhöhte Rohre.

International Bronmetal, S.A. can supply curved and pre-formed tubes.

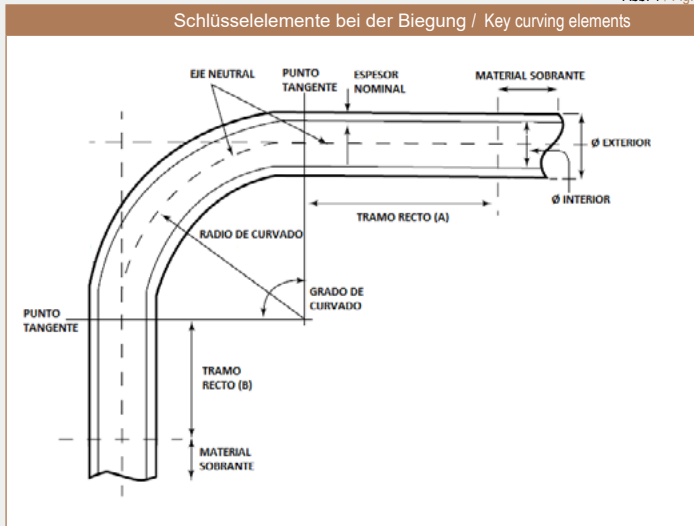

TECHNISCHE EIGENSCHAFTEN 6063 T6 / TECHNICAL FEATURES 6063 T6

Tabelle 5 / Table 5

Bezeichnung / Designation		Physische Eigenschaften / Physical characteristics			Elektrische Eigenschaften / Electrical characteristics		Elektrische Eigenschaften / Static characteristics	
Ø innen / Ø außen / Ø int / Ø ext	Ø außen (mm) / Ø ext. (mm)	Dicke (mm) / Thickness (mm)	Querschnitt (mm ²) / Cross section (mm ²)	Gewicht (g/m) / Weight (g/m)	Zul. Intensität ab 65 °C (A) / Adm. intensity, from 65°C (A)	Zul. Intensität ab 85 °C (A) / Adm. intensity, from 85°C (A)	Massenträgheitsmoment (cm ⁴) / Moment of inertia (cm ⁴)	Steifigkeit (cm ³) / Moment of elasticity (cm ³)
40/36	40	2	239	645	559	742	4,40	2,20
40/34		3	349	942	675	869	6,10	3,10
40/32		4	452	1.221	770	1.014	7,60	3,80
40/30		5	550	1.484	821	1.111	8,80	4,40
40/28		6	641	1.730	869	1.208	9,70	4,90
45/40		45	3	334	901	569	752	7,56
50/44	50	3	443	1.196	773	1.063	12,50	5,00
50/42		4	578	1.561	918	1.208	15,70	6,30
50/40		5	707	1.909	1.014	1.353	18,50	7,40
50/38		6	829	2.239	1.111	1.449	20,80	8,30
50/34		8	1.056	2.850	1.256	1.642	24,60	9,80
50/30		10	1.257	3.393	1.353	1.787	27,20	10,90
60/50	60	5	864	2.333	1.024	1.354	32,93	10,98
63/57	63	3	565	1.527	966	1.304	26,00	8,20
63/55		4	741	2.002	1.111	1.497	33,00	10,50
63/53		5	911	2.460	1.256	1.642	39,30	12,50
63/51		6	1.074	2.901	1.353	1.787	44,90	14,30
63/47		8	1.382	3.732	1.546	2.077	54,40	17,30
68/60		68	4	804	2.171	1.038	1.371	41,34
70/60	70	5	1.021	2.757	1.182	1.563	54,24	15,50
80/74	80	3	726	1.959	1.208	1.594	54,90	13,70
80/72		4	955	2.579	1.353	1.836	70,40	17,60
80/70		5	1.178	3.181	1.497	2.077	84,80	21,20
80/68		6	1.395	3.766	1.642	2.222	97,90	24,50
80/64		8	1.810	4.886	1.884	2.560	121,00	30,20
80/60		10	2.199	5.938	2.077	2.802	140,00	35,00
90/80	90	5	1.335	3.605	1.491	1.971	121,00	26,89
100/94	100	3	914	2.468	1.449	1.932	110,00	21,90
100/92		4	1.206	3.257	1.642	2.222	142,00	28,40
100/90		5	1.492	4.029	1.836	2.512	172,00	34,40
100/88		6	1.772	4.784	1.980	2.705	200,00	40,00
100/84		8	2.312	6.243	2.270	3.140	251,00	50,20
110/100		110	5	1.649	4.453	1.792	2.369	227,81
120/112	120	4	1.458	3.936	1.932	2.608	250,00	41,70
120/110		5	1.806	4.877	2.125	2.947	305,00	50,80
120/108		6	2.149	5.802	2.319	3.188	357,00	59,40
120/104		8	2.815	7.600	2.657	3.671	452,00	75,30
120/100		10	3.456	9.331	2.995	4.058	537,00	89,50
150/136		150	7	3.145	8.491	2.793	3.692	805,76
150/134	8		3.569	9.636	2.976	3.933	902,38	120,32
150/125	13		5.400	14.579	3.660	4.838	1.286,63	171,55
160/152	160	4	1.960	5.293	2.464	3.381	608,00	76,00
160/150		5	2.435	6.574	2.705	3.768	746,00	93,20
160/148		6	2.903	7.838	2.995	4.106	878,00	110,00
160/144		8	3.820	10.314	3.430	4.734	1.127,00	141,00
160/140		10	4.712	12.723	3.816	5.217	1.356,00	170,00
200/190		200	5	3.063	8.270	3.285	4.589	1.484,00
200/188	6		3.657	9.873	3.575	4.927	1.754,00	175,00
200/184	8		4.825	13.029	4.154	5.700	2.269,00	227,00
200/180	10		5.969	16.116	4.589	6.376	2.751,00	275,00
200/176	12		7.087	19.136	5.024	6.956	3.202,00	320,00
250/240	250		5	3.848	10.391	3.961	5.507	2.942,00
250/238		6	4.599	12.418	4.347	6.086	3.489,00	279,00
250/234		8	6.082	16.422	4.927	6.956	4.540,00	363,00
250/230		10	7.540	20.358	5.507	7.729	5.539,00	443,00
250/226		12	8.972	24.225	5.990	8.502	6.487,00	519,00

ANMERKUNG - Die Berechnung der Werte erfolgte gemäß Tabelle 2 ELEKTRISCHE UND MECHANISCHE EIGENSCHAFTEN.

NOTE - Values calculated according to the ELECTRICAL AND MECHANICAL PROPERTIES shown in Table 2



TECHNISCHE EIGENSCHAFTEN 6101 T6 / TECHNICAL FEATURES 6101 T6

Tabelle 6 / Table 6

Bezeichnung / Designation		Physische Eigenschaften / Physical characteristics			Elektrische Eigenschaften / Electrical characteristics		Elektrische Eigenschaften / Static characteristics	
Ø innen / Ø außen / Ø int / Ø ext	Ø außen (mm) / Ø ext. (mm)	Dicke (mm) / Thickness (mm)	Querschnitt (mm ²) / Cross section (mm ²)	Gewicht (g/m) / Weight (g/m)	Zul. Intensität ab 65 °C (A) / Adm. intensity from 65°C (A)	Zul. Intensität ab 85 °C (A) / Adm. intensity from 85°C (A)	Massenträgheitsmoment (cm ⁴) / Moment of inertia (cm ⁴)	Steifigkeit (cm ³) / Moment of elasticity (cm ³)
40/36	40	2	239	645	579	768	4,40	2,20
40/34		3	349	942	699	900	6,10	3,10
40/32		4	452	1.221	797	1.050	7,60	3,80
40/30		5	550	1.484	850	1.150	8,80	4,40
40/28		6	641	1.730	900	1.250	9,70	4,90
45/40	45	3	334	901	589	779	7,56	3,36
50/44	50	3	443	1.196	800	1.100	12,50	5,00
50/42		4	578	1.561	950	1.250	15,70	6,30
50/40		5	707	1.909	1.050	1.400	18,50	7,40
50/38		6	829	2.239	1.150	1.500	20,80	8,30
50/34		8	1.056	2.850	1.300	1.700	24,60	9,80
50/30	10	1.257	3.393	1.400	1.850	27,20	10,90	
60/50	60	5	864	2.333	1.060	1.401	32,93	10,98
63/57	63	3	565	1.527	1.000	1.350	26,00	8,20
63/55		4	741	2.002	1.150	1.550	33,00	10,50
63/53		5	911	2.460	1.300	1.700	39,30	12,50
63/51		6	1.074	2.901	1.400	1.850	44,90	14,30
63/47		8	1.382	3.732	1.600	2.150	54,40	17,30
68/60	68	4	804	2.171	1.074	1.420	41,34	12,16
70/60	70	5	1.021	2.757	1.224	1.618	54,24	15,50
80/74	80	3	726	1.959	1.250	1.650	54,90	13,70
80/72		4	955	2.579	1.400	1.900	70,40	17,60
80/70		5	1.178	3.181	1.550	2.150	84,80	21,20
80/68		6	1.395	3.766	1.700	2.300	97,90	24,50
80/64		8	1.810	4.886	1.950	2.650	121,00	30,20
80/60	10	2.199	5.938	2.150	2.900	140,00	35,00	
90/80	90	5	1.335	3.605	1.544	2.040	121,00	26,89
100/94	100	3	914	2.468	1.500	2.000	110,00	21,90
100/92		4	1.206	3.257	1.700	2.300	142,00	28,40
100/90		5	1.492	4.029	1.900	2.600	172,00	34,40
100/88		6	1.772	4.784	2.050	2.800	200,00	40,00
100/84		8	2.312	6.243	2.350	3.250	251,00	50,20
110/100	110	5	1.649	4.453	1.855	2.452	227,81	41,42
120/112	120	4	1.458	3.936	2.000	2.700	250,00	41,70
120/110		5	1.806	4.877	2.200	3.050	305,00	50,80
120/108		6	2.149	5.802	2.400	3.300	357,00	59,40
120/104		8	2.815	7.600	2.750	3.800	452,00	75,30
120/100		10	3.456	9.331	3.100	4.200	537,00	89,50
150/136	150	7	3.145	8.491	2.891	3.822	805,76	107,43
150/134		8	3.569	9.636	3.080	4.071	902,38	120,32
150/125		13	5.400	14.579	3.789	5.008	1.286,63	171,55
160/152	160	4	1.960	5.293	2.550	3.500	608,00	76,00
160/150		5	2.435	6.574	2.800	3.900	746,00	93,20
160/148		6	2.903	7.838	3.100	4.250	878,00	110,00
160/144		8	3.820	10.314	3.550	4.900	1.127,00	141,00
160/140		10	4.712	12.723	3.950	5.400	1.356,00	170,00
200/190	200	5	3.063	8.270	3.400	4.750	1.484,00	148,00
200/188		6	3.657	9.873	3.700	5.100	1.754,00	175,00
200/184		8	4.825	13.029	4.300	5.900	2.269,00	227,00
200/180		10	5.969	16.116	4.750	6.600	2.751,00	275,00
200/176		12	7.087	19.136	5.200	7.200	3.202,00	320,00
250/240	250	5	3.848	10.391	4.100	5.700	2.942,00	235,00
250/238		6	4.599	12.418	4.500	6.300	3.489,00	279,00
250/234		8	6.082	16.422	5.100	7.200	4.540,00	363,00
250/230		10	7.540	20.358	5.700	8.000	5.539,00	443,00
250/226		12	8.972	24.225	6.200	8.800	6.487,00	519,00

ANMERKUNG - Die Berechnung der Werte erfolgte gemäß Tabelle 2 ELEKTRISCHE UND MECHANISCHE EIGENSCHAFTEN.
NOTE - Values calculated according to the ELECTRICAL AND MECHANICAL PROPERTIES shown in Table 2



MAXIMALE DURCHBIEGUNG INFOLGE DES EIGENGEWICHTS BEI 2 AUFLAGERN / MAXIMUM SAG CAUSED BY THE WEIGHT OF THE STRUCTURE, WITH 2 SUPPORTS

Tabelle 7 / Table 7

Bezeichnung / Designation Ø innen / Ø außen / Ø int / Ø ext	Physische Eigenschaften / Physical characteristics		Maximale Durchbiegung infolge des Eigengewichts bei 2 Auflagern (cm) / Maximum sag caused by the weight of the structure, with 2 supports (cm)					
	Ø außen / Ø ext	Dicke (mm) / Thickness (mm)	Abstand zwischen Auflagern (m) / Distance between supports (m)					
			6	8	10	12	14	20
40/36	40	2						
40/34		3	3,6					
40/32		4	3,8					
40/30		5	4,0		12,7			
40/28		6	4,2		13,3			
45/40	45	3	8,9	21,8				
50/44	50	3	2,3	7,1				
50/42		4	2,4	7,4				
50/40		5	2,4	7,7				
50/38		6	2,5	8,0	19,6			
50/34		8	2,7	8,7	21,2			
50/30	10	2,9	9,3	22,8				
60/50	60	5	1,7	5,3	12,9			
63/57	63	3	1,4	4,4				
63/55		4	1,4	4,5	11,1			
63/53		5	1,5	4,7	11,4			
63/51		6	1,5	4,8	11,8			
63/47		8	1,6	5,1	12,5	26,0		
68/60	68	4	1,2	3,9	9,6	19,9		
70/60	70	5	1,2	3,8	9,3	19,2		
80/74	80	3	0,8	2,7	6,5			
80/72		4	0,9	2,7	6,7	13,9		
80/70		5	0,9	2,8	6,8	14,2		
80/68		6	0,9	2,9	7,0	14,6	27,0	
80/64		8	1,0	3,0	7,4	15,3	28,3	
80/60		10	1,0	3,2	7,7	16,0	29,7	
90/80	90	5	0,7	2,2	5,4	11,3	20,9	
100/94	100	3	0,5	1,7	4,1	8,5		
100/92		4	0,5	1,7	4,2	8,7	16,1	
100/90		5	0,6	1,8	4,3	8,9	16,4	
100/88		6	0,6	1,8	4,4	9,0	16,8	
100/84		8	0,6	1,9	4,5	9,4	17,4	
110/100	110	5	0,5	1,5	3,6	7,4	13,7	
120/112	120	4	0,4	1,2	2,9	6,0	11,0	
120/110		5	0,4	1,2	2,9	6,1	11,2	
120/108		6	0,4	1,2	3,0	6,2	11,4	
120/104		8	0,4	1,3	3,1	6,4	11,8	
120/100		10	0,4	1,3	3,2	6,6	12,2	50,7
150/136	150	7	0,2	0,8	1,9	4,0	7,4	30,8
150/134		8	0,3	0,8	1,9	4,0	7,5	31,2
150/125		13	0,3	0,8	2,1	4,3	7,9	33,1
160/152	160	4	0,2	0,7	1,6	3,3	6,1	25,4
160/150		5	0,2	0,7	1,6	3,3	6,2	25,7
160/148		6	0,2	0,7	1,6	3,4	6,3	26,1
160/144		8	0,2	0,7	1,7	3,5	6,4	26,7
160/140		10	0,2	0,7	1,7	3,6	6,6	27,4
200/190	200	5	0,1	0,4	1,0	2,1	3,9	16,3
200/188		6	0,1	0,4	1,0	2,1	3,9	16,4
200/184		8	0,1	0,4	1,0	2,2	4,0	16,8
200/180		10	0,1	0,4	1,1	2,2	4,1	17,1
200/176		12	0,1	0,4	1,1	2,3	4,2	17,4
250/240	250	5	< 0,1	0,3	0,6	1,3	2,5	10,3
250/238		6	< 0,1	0,3	0,6	1,3	2,5	10,4
250/234		8	< 0,1	0,3	0,7	1,4	2,5	10,6
250/230		10	< 0,1	0,3	0,7	1,4	2,6	10,7
250/226		12	< 0,1	0,3	0,7	1,4	2,6	10,9

NOTA - Wenden Sie sich für Empfehlungen zu ÜBERHÄNGEN an INTERNATIONAL BRONMETAL, S.A.

NOTE - Please contact INTERNATIONAL BRONMETAL, S.A. for more information about the PRE-FORMED TUBE recommendations

Bizkaia

OFICINA/ALMACÉN PRINCIPAL
C/Utxa, 2. Pol. Ind. Sasine
E-48195 LARRABETZU
Bizkaia-SPAIN
Tel.: +34 944 731 500
Fax.: +34 944 117 387
info@ibronmetal.com

C/Bizkargi, 6
Pol. Ind. Sarrikola
E-48195 LARRABETZU
Bizkaia-SPAIN
Tel.: +34 944 731 500
Fax.: +34 944 117 387
info@ibronmetal.com

Barcelona

C/Marconi, 13
Pol. Ind. Sesrovires
E-08635 SANT ESTEVE SESROVIRE
Barcelona-SPAIN
Tel.: +34 937 715 307
Fax.: +34 937 713 866
info@ibronmetal.com

Madrid

C/Nobel, 2-4
Pol. Ind. San Marcos
E-28906 GETAFE
Madrid-SPAIN
Tel.: +34 91 665 25 97
Fax.: +34 91 692 86 74
info@ibronmetal.com

Valencia

C/Mont Cabrer, 22
Pol. Ind. la Lloa
E-46960 ALDAYA
Valencia-SPAIN
Tel.: +34 91 665 25 97
Fax.: +34 91 517 297
info@ibronmetal.com

México

Laurel 207
Fracc. Industrial El Vergel
38110 CELAYA
Guanajuato-MEXICO
Tel.: +52 461 611 06 31
info@ibronmetal.com

Alemania

Robert-Zapp-Straße 5a
40880 RATINGEN
DEUTSCHLAND
Tel.: +49 2102-7142515
Fax: +49 2102-7142518
info@ibronmetal.de